



MAX4173 Evaluation Kit

General Description

The MAX4173 evaluation kit (EV kit) is a fully assembled and tested surface-mount PCB that contains a MAX4173TEUT+. The MAX4173 is a high-side, current-sense amplifier with an input common-mode voltage range that extends from 0 to 28V. The current-sense amplifier provides an analog voltage output proportional to the load current flowing through an external sense resistor.

The 20V/V gain version of the MAX4173 (MAX4173TEUT+) and a 150mΩ sense resistor are installed on the board. Other gain versions of the MAX4173 can be evaluated by replacing the MAX4173TEUT+ with a MAX4173FEUT+ (50V/V) or a MAX4173HEUT+ (100V/V) and a user-supplied, external sense resistor. The user can easily match the full-scale sense voltage to the required output-voltage range.

Features

- ◆ Real-Time Current Monitoring
- ◆ Wide 0 to 28V Input Common-Mode Range Independent of Operating Supply Voltage
- ◆ ±0.5% Full-Scale Accuracy
- ◆ Lead(Pb)-Free and RoHS Compliant
- ◆ Fully Assembled and Tested

Ordering Information

PART	TYPE
MAX4173EVKIT+	EV kit

+Denotes lead(Pb)-free and RoHS compliant.

Component List

DESIGNATION	QTY	DESCRIPTION
C1	1	0.1μF ±10%, 50V X7R ceramic capacitor (0603) Murata GRM188R71H104K
C2	1	4.7μF ±10%, 50V X7R ceramic capacitor (1210) Murata GRM32ER71H475K
C3, C4, C5	0	Not installed, ceramic capacitors (1210)
C6	0	Not installed, ceramic capacitor (0603)
R1	1	0.15Ω ±1%, current-sense resistor (1206) IRC LR1206LF-R150-F

DESIGNATION	QTY	DESCRIPTION
R2, R3, R4	0	Not installed, resistors—short (PC trace) (0603)
RS+, RS-	2	Binding posts
TP1	1	Multipurpose test point, orange
TP2, TP4, TP6	3	Multipurpose test points, black
TP3, TP5	2	Multipurpose test points, red
U1	1	High-side current-sense amplifier (6 SOT23) Maxim MAX4173TEUT+
—	1	PCB: MAX4173 Evaluation Kit+

Component Suppliers

SUPPLIER	PHONE	WEBSITE
IRC, Inc.	361-992-7900	www.irctt.com
Murata Electronics North America, Inc.	770-436-1300	www.murata-northamerica.com

Note: Indicate that you are using the MAX4173 when contacting these component suppliers.

Evaluates: MAX4173

MAX4173 Evaluation Kit

Quick Start

Recommended Equipment

- One 12V, 2A power supply
- One electronic load capable of sinking 1A
- Two digital voltmeters (DVMs)

Procedure

The MAX4173 EV kit is fully assembled and tested. Follow the steps below to verify board operation.

Caution: Do not turn on the power supply or the electronic load until all connections are completed.

- 1) Set the power supply to 12V and connect the positive terminal to test point TP3 (VCC) on the EV kit. Connect the ground of the power supply to test point TP4 (GND) on the EV kit.
- 2) Connect the positive terminal of the 12V power supply to binding post RS+ on the EV kit.
- 3) Set the electronic load to sink 1A.
- 4) Connect the positive terminal of the electronic load to binding post RS- on the EV kit.
- 5) Connect the negative terminal of the electronic load to the ground of the power supply.
- 6) Connect a voltmeter across test point TP5 (RS+) and test point TP6 (RS-).
- 7) Connect the second voltmeter across test points TP1 (OUT) and TP2 (GND).
- 8) Turn on the power supply.
- 9) Turn on the electronic load.
- 10) Verify that the first DVM reading is approximately 150mV and the second DVM is approximately 3V.
- 11) Adjust the electronic load current to between 1A and 0A and verify that the reading of the second DVM is approximately 20 times the reading of the first DVM.

Detailed Description of Hardware

The MAX4173 IC is a current-sense amplifier that measures the load current and provides an analog voltage output. The full-scale V_{SENSE} is set to 150mV. The full-scale I_{SENSE} is set at 1A. They can be changed by replacing current-sense resistor R1 to another appropriate value.

Applying the VCC Power Supply and the Load Power Supply

The MAX4173 EV kit is installed with a MAX4173TEUT+, which has a gain of 20V/V. The current-sense resistor value is 0.15Ω. The V_{OUT} is given by:

$$V_{OUT} = V_{SENSE} \times A_V = I_{SENSE} \times 0.15 \times 20$$

where V_{SENSE} is the sense voltage, I_{SENSE} is the load current, and A_V is the gain of the device.

Normal operating VCC is from 3V to 28V. RS+ and RS- range is 0 to 28V.

Measuring the Load Current

The load current is measured as a voltage drop (V_{SENSE}) across an external sense resistor. This voltage is then amplified by the current-sense amplifier and presented at its OUT pin.

The MAX4173 EV kit, which is assembled with the MAX4173TEUT+, is designed with a full-scale sense voltage drop of 150mV. For a typical 1A full-scale load current, this results in the use of a 0.15Ω sense resistor on the MAX4173 EV kit using the following equation:

$$R1 = \frac{V_{SENSE_FULL_SCALE}}{I_{LOAD_FULL_SCALE}}$$

For different full-scale sense voltage and full-scale load-current arrangements, the equation above can be used to determine the appropriate current-sense-resistor values. Refer to the *Recommended Component Values* section in the MAX4173 IC data sheet for further guidance.

Evaluating the MAX4173FEUT+/MAX4173HEUT+

The MAX4173 EV kit can also be used to evaluate other gain versions of the MAX4173 (20V/V, 50V/V, 100V/V = T, F, H suffix, respectively). Replace U1 with a different version of the MAX4173 and refer to the *Recommended Component Values* section in the MAX4173 IC data sheet for additional information.

MAX4173 Evaluation Kit

Evaluates: **MAX4173**

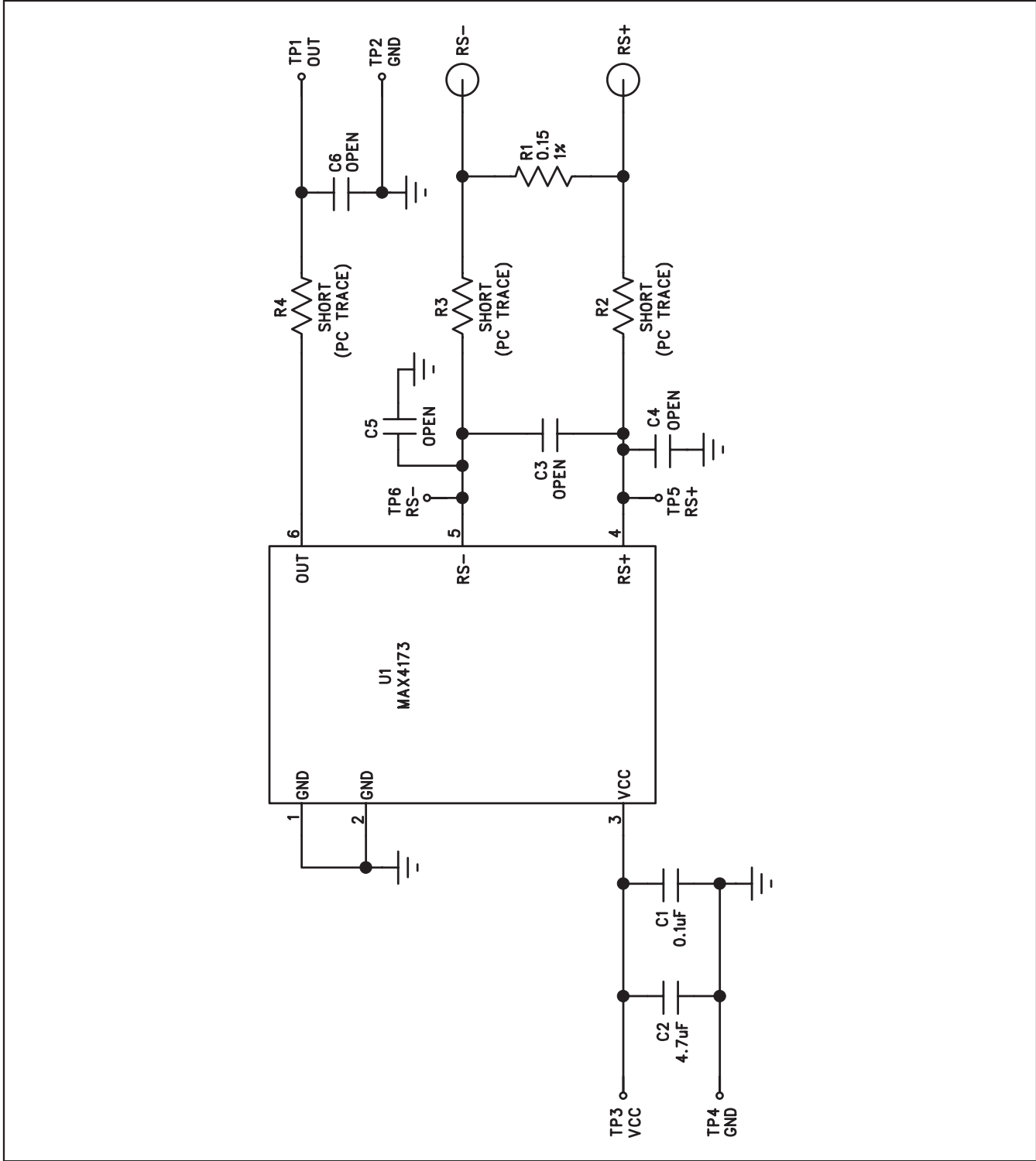

Figure 1. MAX4173 EV Kit Schematic

MAX4173 Evaluation Kit

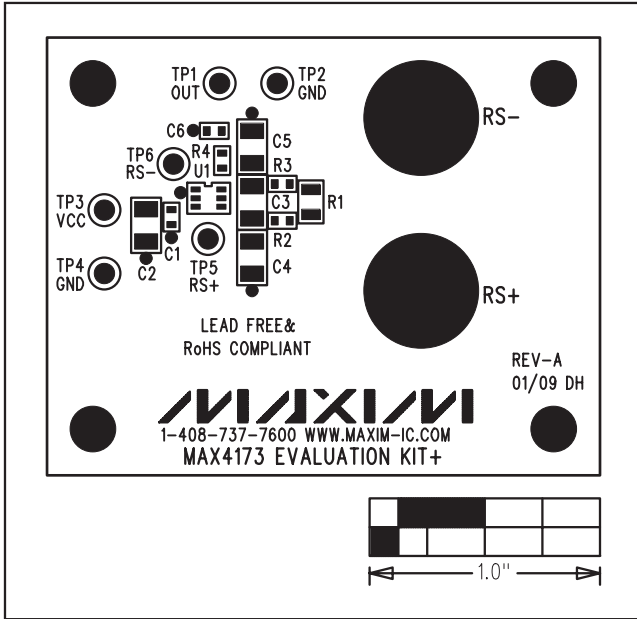

Figure 2. MAX4173 EV Kit Component Placement Guide—Component Side

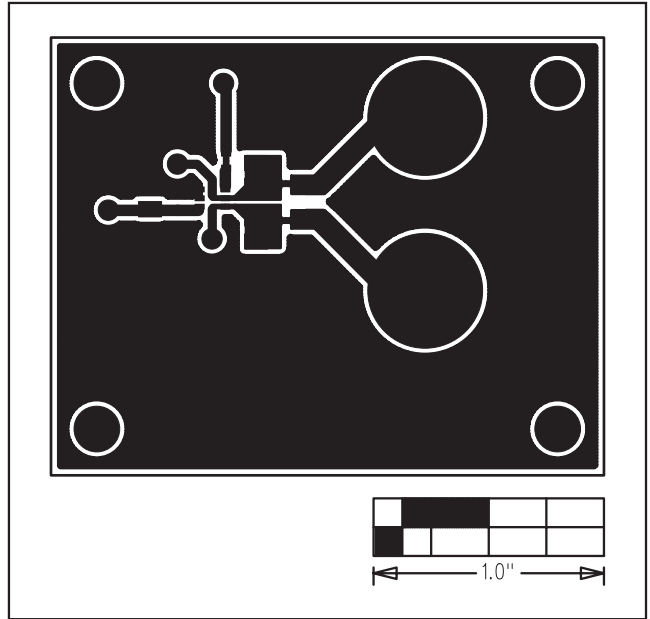

Figure 3. MAX4173 EV Kit PCB Layout—Component Side

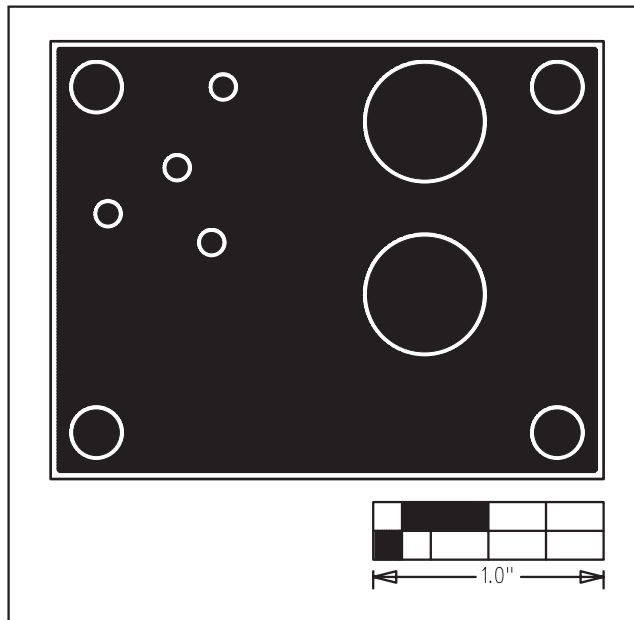

Figure 4. MAX4173 EV Kit PCB Layout—Solder Side

Maxim cannot assume responsibility for use of any circuitry other than circuitry entirely embodied in a Maxim product. No circuit patent licenses are implied. Maxim reserves the right to change the circuitry and specifications without notice at any time.

4 _____ **Maxim Integrated Products, 120 San Gabriel Drive, Sunnyvale, CA 94086 408-737-7600**